



SRT322

User and Installation Instructions

**Battery Powered Wireless Digital Electronic Room
Thermostat with receiver**



The SRT322 is a wireless electronic battery powered room thermostat that uses interoperable two-way RF mesh networking technology to provide optimum comfort with close control of the energy used to heat the home without the need for additional wiring or unsightly cable runs.

The SRT322 will only operate when 2 x AAA batteries have been fitted and the thermostat is installed and communicating with the ASR-ZW receiver unit.

INSTALLATION AND CONNECTION OF THE SRT322 SHOULD ONLY BE CARRIED OUT BY A SUITABLY QUALIFIED PERSON.

DIREKTRONIK

Direktronik AB tel. 08-52 400 700 www.direktronik.se

User Instructions

The Secure SRT322 thermostat uses the latest control technology to provide extremely accurate temperature control which will help to keep your energy usage as low as possible without affecting your comfort levels. In fact comfort levels may well be improved as the control accuracy should ensure that the room does not 'overheat' before switching off.



The display will show the required temperature setting and can be adjusted in increments of 1°C.

To adjust the required temperature setting turn the dial anti clockwise to decrease it and clockwise to increase it.



Pressing the temperature setting dial will allow the user to check the current actual measured room temperature which will be displayed for approx 7 seconds before returning to the set temperature.



When the thermostat is in the 'call for heat' condition a flame symbol will appear in the display.



The aerial symbol complete with radio wave symbols in the display of the SRT322 thermostat indicates that it is communicating satisfactorily with the receiver.

A flashing radio wave indicates a loss of communication. This may be temporary and can often be restored by turning the thermostat dial and increasing or decreasing the temperature to make the thermostat switch. If this has no effect please see Z-Wave pairing instructions on page 10.



A radio mast symbol with no radio waves indicates that the SRT322 has not been signed on to enable it to communicate with the receiver. In this case you may wish to contact the Installer as the indication is that the product has not been commissioned when the installation took place. Alternatively see the Z-Wave pairing instructions on page 10.

Battery replacement

The SRT322 runs on 2 x type AAA (Alkaline) non rechargeable batteries and is designed to give a battery life of approximately two years.

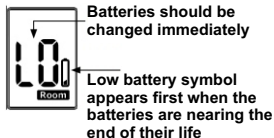

When the batteries are nearing the end of their life a low battery symbol will appear in the display and the batteries should be changed within a few days. If the batteries are not changed at this point eventually a 'LO' battery message flashes intermittently in the display and if this happens the batteries should be changed immediately.

To change the batteries it is necessary to remove the thermostat from the wall. To do this first undo the two captive screws at the base of the thermostat and swing the thermostat up and away from the wall plate.

Remove the old batteries and replace them with two new AAA size alkaline batteries ensuring that they are fitted correctly as indicated by the terminal markings in the battery compartments.

Once the batteries are fitted, re-fit the thermostat to the wall plate by engaging with the lugs at the top of the wall plate and push the thermostat into position. Locate it over the captive screws at the base of the wall plate and tighten so that the thermostat is locked into position.



Check the temperature setting is correct and adjust if necessary.

Please dispose off the batteries responsibly 

Receiver unit



The receiver unit receives the Z-Wave radio signals from the SRT322 room thermostat. In the unlikely event of a communication failure it is possible to override the system and switch On and Off using the On/Off buttons on the receiver as a local override.

If the override is used to override the SRT322 thermostat when it is functioning correctly then the override will be cancelled by the next switching operation of the thermostat and normal operation will be resumed. In any case, with no further intervention, normal operation will be restored within one hour of the override being operated.

Installation Instructions

Installing the Receiver

The receiver should be located as near as is practical to the boiler or zone valve to be controlled, as well as a convenient mains electricity supply. To remove the wall plate from the receiver, undo the two retaining screws located on the underside, the wall plate should now be easily removed. Once the wall plate has been removed from the packaging please ensure the receiver is re-sealed to prevent damage from dust, debris etc.

The wall plate should be fitted with the retaining screws located at the bottom and in a position which allows a total clearance of at least 50mm around the receiver.

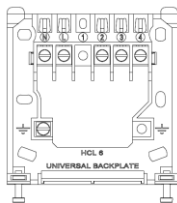

Direct Wall Mounting

Offer the plate to the wall in the position where the receiver is to be mounted and mark the fixing positions through the slots in the wall plate. Drill and plug the wall, then secure the plate into position. The slots in the wall plate will compensate for any misalignment of the fixings.

Wall Box Mounting

The wall plate may be fitted directly on to a single gang flush wiring box complying with BS4662, using two M3.5 screws. The receiver is suitable for mounting on a flat surface only; it is not suitable for mounting on an unearthed metal surface.

Electrical Connections

WARNING: ISOLATE THE MAINS SUPPLY BEFORE COMMENCING INSTALLATION

As the SRT322 is a wireless product with no electrical connections all electrical wiring will be made to the receiver.

All necessary electrical connections should now be made. Flush wiring can enter from the rear through the aperture in the backplate.

The mains supply terminals are intended to be connected to the supply by means of fixed wiring.

The receiver is mains powered and requires a 3 Amp fused spur.
The recommended cable size is 1.0mm².

The receiver is double insulated and does not require an earth connection, an earth connection block is provided on the backplate for terminating any cable earth conductors. Earth continuity must be maintained and all bare earth conductors must be sleeved. Ensure that no conductors are left protruding outside the central space enclosed by the backplate.

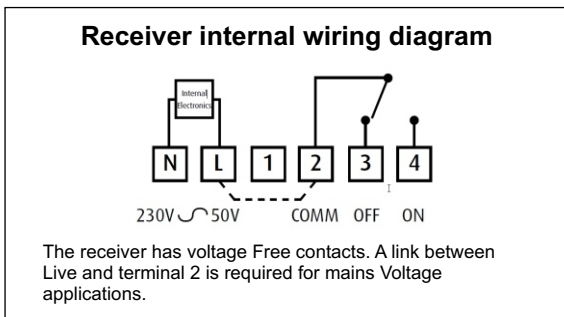

Two example circuit diagrams for typical boiler installations are shown opposite. These diagrams are schematic and should be used for guidance only. Please ensure that all installations comply with the current IEE regulations and the boiler manufacturer's installation instructions.

For reasons of space and clarity not every connection has been included and the diagrams have been simplified, for instance some earth connections have been omitted.

Typical combi boiler system with built in timer

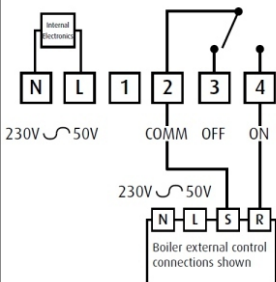

This diagram shows a typical receiver and combination boiler installation, where the external boiler control is connected via switching terminals (a link may have to be removed on the boiler switching control terminals). Mains supplies to both the receiver and the boiler are omitted for clarity. Please consult the boiler manufacturers installation handbook before commencing any installation work.

N = Neutral
L = Live
S = Boiler switch output
R = Boiler switch return

Zone/Heating control basic layout

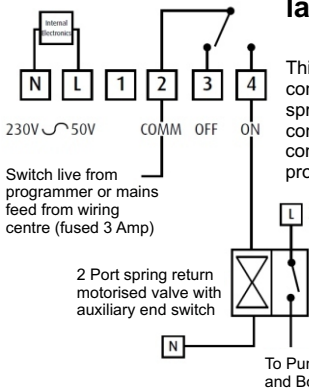

This diagram shows a receiver used in a conventional fully pumped system using a 2 port spring return zone valve with auxiliary switch to control the pump and boiler. Please note: hot water control will need to be controlled by the use of a programmer or time switch.

Mains supplies to both the receiver and the boiler are omitted for clarity. Please consult the boiler manufacturers installation handbook before commencing any installation work.

Fitting the SRT322 Room Thermostat

Before final installation it is advisable to commission the product and ensure that the Thermostat and Receiver are communicating satisfactorily. First install the 2 x type AAA batteries provided making sure that they are fitted correctly as indicated by the markings in the battery compartment. Once the thermostat and receiver are successfully 'paired' the thermostat can be installed in its correct location. Please see Z-Wave pairing instructions on page 10.

Avoid installing the thermostat against or behind any large metal surfaces which could interfere with the radio signals to and from the receiver. The SRT322 should be mounted on an internal wall approximately 1.5 metres from floor level using the wall plate provided and should be in a position away from draughts, direct heat and sunlight. Ensure that there will be enough space to allow easy access to the two retaining screws located at the base of the wall plate.

Before fixing the wall plate in position check to see that the thermostat and Receiver are still able to communicate satisfactorily by turning the thermostat temperature up and down to switch the receiver on and off.

Offer the plate to the wall in the position where the receiver is to be mounted and mark the fixing positions through the slots in the wall plate. Drill and plug the wall, then secure the plate into position. The slots in the wall plate will compensate for any misalignment of the fixings.

Complete the installation by swinging the room thermostat into position by engaging with the lugs at the top of the wall plate before pushing it carefully into its plug-in terminal block.

Tighten the 2 captive screws on the underside of the metal.

Now ensure that the heating system is responding to the ON/OFF commands from the Room Thermostat and explain its operation to the householder before handing over these User Instructions.

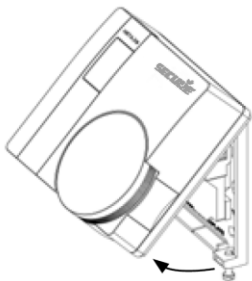
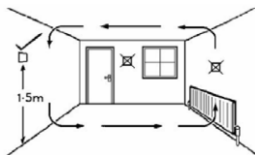

DIL switch settings – TPI temperature control software

Thermostats using TPI (Time Proportional Integral) control algorithms will reduce the temperature swing that normally occurs when using traditional bellows or thermally operated thermostats.

As a consequence, a TPI regulating thermostat will maintain the comfort level far more efficiently than any traditional thermostat.

When used with a condensing boiler, the TPI thermostat will help to save energy as the control algorithm allows the boiler to operate in condensing mode more consistently compared to older types of thermostat.

- DIL switch numbers 7 and 8 should be set as diagram opposite.
- For Gas boilers set the TPI setting to 6 cycles per hour. (Default setting)
- For Oil boilers set the TPI setting to 3 cycles per hour.
- For Electric heating set the TPI setting to 12 cycles per hour.

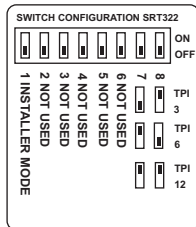

Switch positions for different TPI settings.

Instructions for pairing the SRT322 room thermostat with the receiver

The SRT322 uses the latest Z-Wave wireless communication technology to give a reliable wireless link that should not suffer from interference from other nearby devices. The device comprises of a thermostat and its receiver unit. Pairing the devices on site ensures reliable communication.

Follow these steps to ensure that the SRT322 thermostat will communicate satisfactorily with it's receiver, this is best carried out with the SRT322 Thermostat held nearby the (powered) receiver.

Stage 1

- 1) Set the number 1 DIL switch on the back of the SRT322 thermostat to the On (Up) position and the display on the SRT322 will change to show the letter 'I'. If the letter 'L' appears, carry out stage 1A opposite.

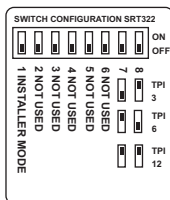

- 2) Power up the receiver unit.
- 3) The network LED on the receiver should be flashing.
- 4) Press the dial on the front of the SRT322 thermostat once so that the 'I' in the display flashes.
- 5) Press and hold the network button on the receiver until the On indicator flashes (green) before the Off indicator becomes solid red.

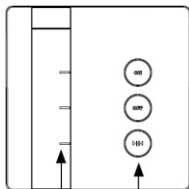

Network LED Network button

- 6) After a few seconds the radio mast symbol  will appear in the display along with the letters IP.
- 7) Reset the number 1 DIL switch on the back of the SRT322 to the Off position and the temperature should return in the display.
- 8) Now check the receiver responds to the thermostat on and off commands by increasing and decreasing the temperature settings until it switches accordingly.

N.B. There is a half second delay in switching On and Off on receipt of the command.

- 9) The Z-Wave communication link is now successfully established.

Under normal circumstances the SRT322 thermostat and receiver will be 'paired' easily by following the procedure shown under Stage 1 of the pairing instructions.

Only use Stage 2 if a radio link cannot be successfully established between the two devices.

Stage 1A – Only used if 'L' is displayed instead of 'I'

- 1) Turn the dial of the SRT322 until the letter P appears in the display.
- 2) Press the dial twice.
- 3) A second P should appear in the display which now shows 'PP'.
- 4) Turn the dial until the letter 'I' appears in the display and return to the main instruction.

Stage 2 – Only used if the above procedure does not establish a successful communication link

- 1) Turn the dial until the letter P appears in the display.
- 2) Press the dial twice and PP should appear in the display.
- 3) Now turn the dial until letter E appears in the display.
- 4) Press the dial once and the display should flash.
- 5) Press and hold the network button on the receiver until it starts to flash.
- 6) Turn the dial until the letter 'I' appears in the display and return to the main instruction.

Thermostat specifications

Power supply	2 x AAA alkaline batteries
Temperature accuracy	+/- 0.5 °C
Transmitter frequency	868MHz
Dimensions	86mm x 86mm x36.25mm
Pollution control	Degree2
Design standard	EN60730 - 2-9
Temperature range	5 °C – 30 °C
Rated Impulse voltage	Cat 1 – 1500v
Enclosure protection	IP30
Operating temperature range	0-40 °C
Double Insulated	
Case material	Thermoplastic, flame retardant

Receiver specification

Power Supply	230V AC 50Hz
Contact type	Micro disconnection
	Voltage free
Contact rating	3 (1) Amps 230v AC
Operating temperature range	0-40 °C
Double Insulated	
Rated Impulse voltage	Cat 1 – 1500v
Pollution control	Degree2
Enclosure protection	IP30
Case material	Thermoplastic, flame retardant
Dimensions	86mm x 86mm x 36.25mm

The logo for DIREKTRONIK is displayed in a bold, italicized, red font with a white outline. It is positioned on a yellow curved background that sweeps across the bottom of the page.

Direktronik AB tel. 08-52 400 700 www.direktronik.se